

Stock Items available in carbon steel and 302 stainless steel.

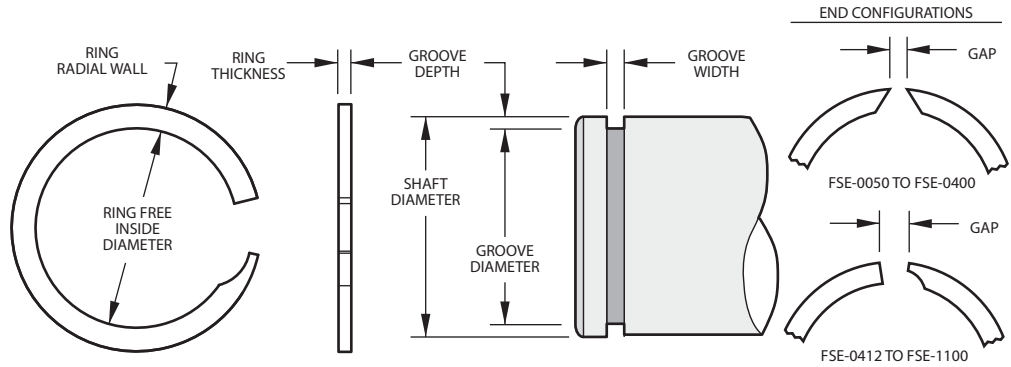
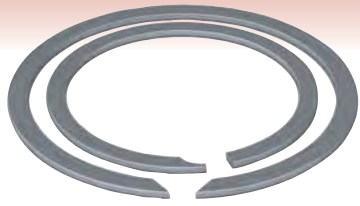

Product Dimensions All dimensions are in inches unless otherwise specified.

Smalley Part Number ^{1,4}	Shaft Diameter	Ring			Groove		Thrust Capacity	
		Inside Diameter	Radial Wall	Thickness	Diameter	Width	Groove Yield (lb) ²	Ring Shear (lb) ³
FSE-0050	.500	.471	.055	.037	.476	.043	424	2,325
FSE-0056	.562	.524	.055	.037	.532	.043	596	2,613
FSE-0062	.625	.590	.065	.037	.595	.043	663	2,906
FSE-0068	.687	.649	.065	.037	.655	.043	777	3,194
FSE-0075	.750	.701	.075	.045	.710	.051	1,060	4,241
FSE-0081	.812	.764	.075	.045	.772	.051	1,148	4,592
FSE-0087	.875	.820	.075	.045	.831	.051	1,361	4,948
FSE-0093	.937	.886	.085	.045	.893	.051	1,457	5,334
FSE-0100	1.000	.933	.085	.045	.952	.051	1,696	5,693
FSE-0106	1.062	1.004	.085	.045	1.014	.051	1,802	6,045
FSE-0112	1.125	1.069	.128	.057	1.077	.063	1,909	7,615
FSE-0118	1.187	1.116	.128	.057	1.131	.063	2,349	8,035
FSE-0125	1.250	1.176	.128	.057	1.188	.063	2,739	8,461
FSE-0131	1.312	1.223	.128	.057	1.242	.063	3,246	8,881
FSE-0137	1.375	1.282	.128	.057	1.297	.063	3,791	9,307
FSE-0143	1.437	1.344	.158	.067	1.359	.073	3,961	11,408
FSE-0150	1.500	1.402	.158	.067	1.422	.073	4,135	11,908
FSE-0156	1.562	1.457	.158	.067	1.470	.073	5,079	12,400
FSE-0162	1.625	1.517	.158	.067	1.533	.073	5,284	12,901
FSE-0168	1.687	1.578	.158	.067	1.595	.073	5,485	13,393
FSE-0175	1.750	1.640	.158	.067	1.658	.073	5,690	13,893
FSE-0181	1.812	1.697	.158	.067	1.720	.073	5,892	14,385
FSE-0187	1.875	1.767	.158	.067	1.783	.073	6,097	14,885
FSE-0193	1.937	1.800	.200	.076	1.819	.085	8,078	16,649
FSE-0200	2.000	1.862	.200	.076	1.882	.085	8,341	17,191
FSE-0206	2.062	1.924	.200	.076	1.944	.085	8,599	17,724
FSE-0212	2.125	1.987	.200	.076	2.007	.085	8,862	18,265
FSE-0218	2.187	2.048	.200	.076	2.069	.085	9,121	18,798
FSE-0225	2.250	2.110	.200	.076	2.132	.085	9,384	19,340
FSE-0231	2.312	2.171	.200	.076	2.194	.085	9,642	19,873
FSE-0237	2.375	2.226	.200	.076	2.257	.085	9,905	20,414
FSE-0243	2.437	2.296	.200	.076	2.319	.085	10,163	20,947
FSE-0250	2.500	2.357	.200	.076	2.382	.085	10,426	21,488
FSE-0256	2.562	2.415	.200	.095	2.444	.104	10,685	26,252
FSE-0262	2.625	2.486	.200	.095	2.507	.104	10,947	26,898
FSE-0268	2.687	2.537	.200	.095	2.569	.104	11,206	27,533
FSE-0275	2.750	2.607	.200	.095	2.632	.104	11,469	28,179
FSE-0281	2.812	2.665	.200	.095	2.694	.104	11,727	28,814
FSE-0287	2.875	2.727	.200	.095	2.757	.104	11,990	29,460
FSE-0293	2.937	2.789	.200	.095	2.819	.104	12,249	30,095

¹ Add suffix "-S02" for 302 stainless steel.

² Based on a groove material yield strength of 45,000 psi and a safety factor of 2.

³ Based on a safety factor of 3.

⁴ See pages 126-127 for How to Order.

Stock Items available in carbon steel and 302 stainless steel.

Product Dimensions All dimensions are in inches unless otherwise specified.

Smalley Part Number ^{1,4}	Shaft Diameter	Ring			Groove		Thrust Capacity	
		Inside Diameter	Radial Wall	Thickness	Diameter	Width	Groove Yield (lb) ²	Ring Shear (lb) ³
FSE-0300	3.000	2.852	.200	.095	2.882	.104	12,511	30,740
FSE-0306	3.062	2.916	.200	.095	2.944	.104	12,770	31,376
FSE-0312	3.125	2.955	.237	.095	2.987	.104	15,242	32,021
FSE-0318	3.187	3.016	.237	.095	3.049	.104	15,544	32,657
FSE-0325	3.250	3.079	.237	.095	3.112	.104	15,851	33,302
FSE-0331	3.312	3.140	.248	.115	3.174	.124	16,154	39,088
FSE-0337	3.375	3.203	.248	.115	3.237	.124	16,461	39,831
FSE-0343	3.437	3.264	.248	.115	3.299	.124	16,763	40,563
FSE-0350	3.500	3.326	.248	.115	3.362	.124	17,071	41,307
FSE-0356	3.562	3.378	.248	.115	3.424	.124	17,373	42,038
FSE-0362	3.625	3.451	.248	.115	3.487	.124	17,680	42,782
FSE-0368	3.687	3.512	.248	.115	3.549	.124	17,983	43,514
FSE-0375	3.750	3.570	.248	.115	3.612	.124	18,290	44,257
FSE-0381	3.812	3.636	.248	.115	3.674	.124	18,592	44,989
FSE-0387	3.875	3.689	.248	.115	3.737	.124	18,900	45,732
FSE-0393	3.937	3.760	.248	.115	3.799	.124	19,202	46,464
FSE-0400	4.000	3.828	.248	.115	3.862	.124	19,509	47,208
FSE-0412	4.125	3.930	.265	.153	3.967	.163	23,035	62,126
FSE-0425	4.250	4.050	.265	.153	4.092	.163	23,733	64,008
FSE-0437	4.375	4.174	.265	.153	4.217	.163	24,431	65,891
FSE-0450	4.500	4.297	.265	.153	4.342	.163	25,129	67,774
FSE-0462	4.625	4.421	.265	.153	4.467	.163	25,827	69,656
FSE-0475	4.750	4.530	.265	.153	4.592	.163	26,525	71,539
FSE-0487	4.875	4.668	.265	.153	4.717	.163	27,223	73,421
FSE-0500	5.000	4.792	.265	.153	4.842	.163	27,921	75,304
FSE-0525	5.250	5.039	.265	.153	5.092	.163	29,317	79,069
FSE-0550	5.500	5.292	.265	.153	5.342	.163	30,713	82,834
FSE-0575	5.750	5.535	.265	.153	5.592	.163	32,109	86,599
FSE-0600	6.000	5.744	.316	.153	5.804	.163	41,563	90,365
FSE-0625	6.250	5.992	.316	.153	6.054	.163	43,295	94,130
FSE-0650	6.500	6.236	.316	.153	6.304	.163	45,027	97,895
FSE-0675	6.750	6.486	.316	.153	6.554	.163	46,759	101,727
FSE-0700	7.000	6.734	.316	.153	6.804	.163	48,490	105,494
FSE-0725	7.250	6.993	.316	.153	7.054	.163	50,222	109,262
FSE-0750	7.500	7.219	.316	.153	7.304	.163	51,954	113,030
FSE-0775	7.750	7.477	.316	.153	7.554	.163	53,686	116,797
FSE-0800	8.000	7.683	.435	.192	7.764	.203	66,727	142,932
FSE-0825	8.250	7.940	.435	.192	8.014	.203	68,813	147,399
FSE-0850	8.500	8.179	.435	.192	8.264	.203	70,898	151,866
FSE-0875	8.750	8.427	.435	.192	8.514	.203	72,983	156,332
FSE-0900	9.000	8.673	.435	.192	8.764	.203	75,068	160,799
FSE-0925	9.250	8.922	.435	.192	9.014	.203	77,154	165,265
FSE-0950	9.500	9.130	.435	.192	9.240	.203	87,297	169,732
FSE-0975	9.750	9.393	.435	.192	9.490	.203	89,594	174,199
FSE-1000	10.000	9.586	.500	.192	9.686	.203	110,977	178,665
FSE-1025	10.250	9.826	.500	.192	9.936	.203	113,751	183,132
FSE-1050	10.500	10.081	.500	.192	10.186	.203	116,526	187,599
FSE-1075	10.750	10.329	.500	.192	10.436	.203	119,300	192,065
FSE-1100	11.000	10.584	.500	.192	10.686	.203	122,074	196,532

¹ Add suffix "-S02" for 302 stainless steel.

² Based on a groove material yield strength of 45,000 psi and a safety factor of 2.

³ Based on a safety factor of 3.

⁴ See pages 126-127 for How to Order.