

Stock Items in carbon steel and 17-7 PH/C stainless steel. Springs listed below are 3 wave, **Overlap Type**.

Smalley Part Number ^{1,4}	Operates in Bore Diameter	Clears Shaft Diameter	Load (lb)	Work Height	Free Height ²	Number of Waves	Thickness	Radial Wall	Spring Rate ³
SSR-0050	.500	.390	7	.050	.085	3	.008	.040	200
SSR-0062	.625	.480	10	.050	.095	3	.010	.058	222
SSR-0075	.750	.500	14	.062	.160	3	.010	.078	143
SSR-0087	.875	.620	16	.062	.130	3	.012	.094	235
SSR-0100	1.000	.780	18	.062	.160	3	.012	.094	184
SSR-0112	1.125	.840	20	.078	.130	3	.016	.133	385
SSR-0125	1.250	.960	22	.078	.150	3	.016	.133	306
SSR-0137	1.375	1.090	24	.078	.190	3	.016	.133	214
SSR-0150	1.500	1.170	26	.078	.170	3	.018	.143	283
SSR-0162	1.625	1.310	28	.078	.200	3	.018	.143	230

¹ Add suffix "-S17" for 17-7 stainless steel.

² Reference dimension.

³ Theoretical dimension; measured in lb/in.

⁴ See pages 126-127 for How to Order.

OVERLAP TYPE

SSR-0050 to SSR-0162

Product Dimensions

All dimensions in inches unless otherwise specified.

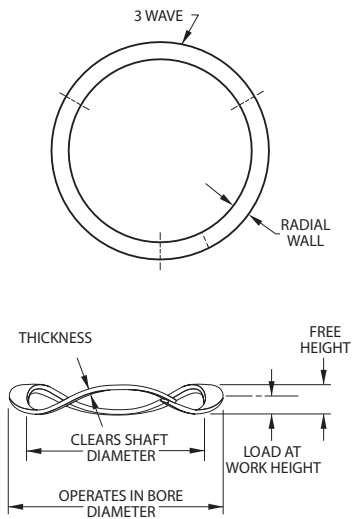

Bayonet Connector

Stock Items in carbon steel and 17-7 PH/C stainless steel. Springs listed below are 4 waves and up, **Gap Type**.

Smalley Part Number ^{1,4}	Operates in Bore Diameter	Clears Shaft Diameter	Load (lb)	Work Height	Free Height ²	Number of Waves	Thickness	Radial Wall	Spring Rate ³
SSR-0175	1.750	1.440	30	.078	.140	4	.018	.143	484
SSR-0187	1.875	1.560	32	.078	.150	4	.018	.143	444
SSR-0200	2.000	1.680	34	.093	.140	4	.024	.150	723
SSR-0212	2.125	1.800	36	.093	.150	4	.024	.150	632
SSR-0225	2.250	1.930	38	.093	.170	4	.024	.150	494
SSR-0237	2.375	1.990	40	.093	.160	4	.024	.178	597
SSR-0250	2.500	2.120	42	.093	.170	4	.024	.178	545
SSR-0262	2.625	2.240	44	.093	.190	4	.024	.178	454
SSR-0275	2.750	2.340	46	.109	.170	4	.030	.188	754
SSR-0287	2.875	2.470	48	.109	.180	4	.030	.188	676
SSR-0300	3.000	2.590	50	.109	.190	4	.030	.188	617
SSR-0312	3.125	2.710	52	.109	.210	4	.030	.188	515
SSR-0325	3.250	2.750	54	.109	.200	4	.030	.233	593
SSR-0337	3.375	2.840	56	.109	.220	4	.030	.233	505
SSR-0350	3.500	3.000	58	.109	.230	4	.030	.233	479
SSR-0362	3.625	3.120	60	.109	.240	4	.030	.233	458
SSR-0375	3.750	3.250	62	.109	.260	4	.030	.233	411
SSR-0387	3.875	3.370	64	.109	.300	4	.030	.233	335
SSR-0400	4.000	3.500	66	.109	.190	5	.030	.233	815
SSR-0412	4.125	3.620	67	.109	.200	5	.030	.233	736
SSR-0425	4.250	3.740	69	.109	.210	5	.030	.233	683
SSR-0437	4.375	3.860	70	.109	.210	5	.030	.233	693
SSR-0450	4.500	3.990	72	.109	.230	5	.030	.233	595
SSR-0462	4.625	4.110	73	.125	.270	5	.030	.233	503
SSR-0475	4.750	4.240	75	.125	.310	5	.030	.233	405
SSR-0487	4.875	4.370	76	.125	.290	5	.030	.233	461
SSR-0500	5.000	4.490	78	.125	.310	5	.030	.233	422
SSR-0512	5.125	4.610	80	.125	.340	5	.030	.233	372
SSR-0525	5.250	4.740	82	.125	.370	5	.030	.233	335
SSR-0537	5.375	4.860	84	.125	.380	5	.030	.233	329
SSR-0550	5.500	4.990	86	.125	.250	6	.030	.233	688
SSR-0562	5.625	5.110	88	.125	.270	6	.030	.233	607
SSR-0575	5.750	5.240	90	.125	.280	6	.030	.233	581
SSR-0587	5.875	5.360	92	.125	.300	6	.030	.233	526
SSR-0600	6.000	5.490	94	.125	.300	6	.030	.233	537
SSR-0612	6.125	5.610	96	.125	.310	6	.030	.233	519
SSR-0625	6.250	5.730	98	.125	.340	6	.030	.233	456
SSR-0637	6.375	5.860	100	.125	.350	6	.030	.233	444
SSR-0650	6.500	5.980	102	.125	.390	6	.030	.233	385
SSR-0675	6.750	6.230	104	.125	.420	6	.030	.233	353
SSR-0700	7.000	6.160	106	.156	.320	6	.032	.375	646
SSR-0725	7.250	6.440	108	.156	.350	6	.032	.375	557
SSR-0750	7.500	6.690	110	.156	.360	6	.032	.375	539
SSR-0775	7.750	6.940	114	.156	.380	6	.032	.375	509
SSR-0800	8.000	7.190	118	.156	.390	6	.032	.375	504
SSR-0825	8.250	7.440	122	.156	.430	6	.032	.375	445
SSR-0850	8.500	7.680	126	.156	.340	7	.032	.375	685
SSR-0875	8.750	7.930	130	.156	.340	7	.032	.375	707
SSR-0900	9.000	8.180	134	.156	.290	8	.032	.375	1,000
SSR-0950	9.500	8.680	142	.156	.240	9	.032	.375	1,690
SSR-1000	10.000	9.170	150	.156	.290	9	.032	.375	1,119
SSR-1050	10.500	9.670	158	.156	.310	9	.032	.375	1,026
SSR-1100	11.000	10.170	166	.156	.350	9	.032	.375	856
SSR-1150	11.500	10.660	174	.156	.360	9	.032	.375	853
SSR-1200	12.000	11.160	182	.156	.440	9	.032	.375	641
SSR-1250	12.500	11.660	190	.156	.350	10	.032	.375	979
SSR-1300	13.000	12.160	198	.156	.410	10	.032	.375	780
SSR-1350	13.500	12.650	206	.156	.430	10	.032	.375	752
SSR-1400	14.000	13.150	214	.156	.300	12	.032	.375	1,486
SSR-1450	14.500	13.650	221	.156	.320	12	.032	.375	1,348
SSR-1500	15.000	14.130	230	.156	.350	12	.032	.375	1,186
SSR-1550	15.500	14.640	239	.156	.310	13	.032	.375	1,552
SSR-1600	16.000	15.140	248	.156	.340	13	.032	.375	1,348

¹ Add suffix "-S17" for 17-7 stainless steel.

² Reference dimension.

³ Theoretical dimension; measured in lb/in.

⁴ See pages 126-127 for How to Order.

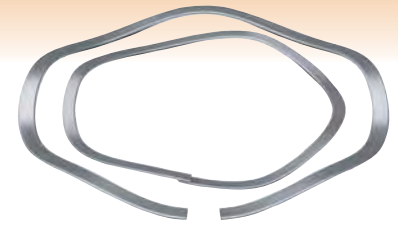

GAP TYPE

SSR-0175 to SSR-1600

Product Dimensions

All dimensions in inches unless otherwise specified.

